

**Tracing Electroadhesion from Classical Electrostatics to Smart Adhesives and Robo Grippers:
Building the Bridges With ChatGPT**

Chitnarong Sirisathitkul¹, Yaowarat Sirisathitkul^{2*}

¹ *School of Science, Walailak University, Nakhon Si Thammarat, 80160, Thailand*

² *School of Engineering and Technology, Walailak University, Nakhon Si Thammarat, 80160, Thailand*

*Corresponding author's email: syaowara@mail.wu.ac.th

Received: Sep 07, 2025 **Revised:** Jun 30, 2026 **Just Accepted Online:** Jul 10, 2026 **Published:** Xxx

This article has been accepted for publication and undergone full peer review but has not been through the copyediting, typesetting, pagination and proofreading process, which may lead to differences between this version and the Version of Record.

Please cite this article as:

C. Sirisathitkul, Y. Sirisathitkul (2026) Tracing Electroadhesion from Classical Electrostatics to Smart Adhesives and Robo Grippers: Building the Bridges With ChatGPT. **Substantia**. *Just Accepted*. DOI: 10.36253/Substantia-3754

Abstract Electroadhesion has emerged as a promising mechanism in a growing range of applications, from smart adhesives and wall-climbing robots to robo grippers that reversibly grip or release objects with the flick of a switch. The development of autonomous and adaptive electroadhesive systems—capable of adjusting to varying materials and environmental conditions—represents a promising frontier

in material science and robotics. These innovations are powered by electrostatic forces first observed millennia ago in rubbed amber. This article offers a synthetic and historically informed account tracing the evolution from early electrostatic observations to contemporary smart adhesive materials and robotic applications. Beyond consulting indexed journal articles, we engage in Socratic-style dialogue with ChatGPT to tap into its broad training corpus. This method helps uncover overlooked historical threads, cross-disciplinary linkages, and thematic continuities spanning centuries. In doing so, we also reflect on the emerging role of large language model (LLM) in scientific historiography. Our collaboration with ChatGPT not only shapes the structure of this narrative but also serves as a case study in how LLM can support integrative, cross-disciplinary writing in the history of material chemistry and technology.

Keywords: Electroadhesion, Material chemistry, Smart adhesive, Electrostatic robo gripper, ChatGPT

1. INTRODUCTION

The phenomenon of adhesion—material sticking together through physical or chemical means [1]—is deeply familiar, yet its historical connection with electrostatics remains relatively underexplored. Electroadhesion, where electrostatic forces enable reversible attachment, has increasingly been implemented in robotics, wearable interfaces, and biomedical devices [2,3]. Rather than relying on glue or mechanical interlocking, these technologies use electrostatic attraction to grip and lift objects across diverse applications. Their advantages include adaptability, low energy consumption, and the gentle handling of delicate materials. Ongoing advancements are expanding the capabilities of electroadhesion, addressing existing challenges, and paving the way for wider adoption in robotics and human–machine interfaces [2,3]. In particular, combining electroadhesive materials with soft robotic technologies enhances the ability to manipulate objects in complex or confined environments, highlighting their importance in modern technology and manufacturing.

Yet the conceptual and material roots of electroadhesion lie deep within the history of electrostatics—stretching back to ancient observations of amber’s attractive properties. While electrostatics is among the oldest identified branches of physical science [4], its modern applications are typically associated with electrophotography electrostatic precipitation, painting and coating [5,6]. The broader historical lineage—linking ancient discoveries to current innovations—has often been overlooked.

This article traces the arc from classical electrostatics to 21st-century electroadhesion technologies, emphasizing the interplay between historical insight and modern innovation. Central to this exploration is our collaboration with ChatGPT, a large language model (LLM) trained on a vast corpus of scientific, historical, and technical texts. Rather than relying solely on keyword-based database searches, we engaged in Socratic-style dialogue with ChatGPT, as demonstrated in other domains [7], to uncover conceptual connections, forgotten experiments, and thematic continuities that span physics, chemistry, and material science. This deep continuity—from rubbed amber to surface-charged elastomers—is insufficiently acknowledged in contemporary scientific literature, where specialization often obscures historical context. By stepping back and using LLM-powered chatbots like ChatGPT as a reflective partner, we aim to build bridges across disciplines and centuries. In doing so, we recover a narrative that reunites the chemistry of adhesion and the physics of electrostatics, restoring them to their shared conceptual roots.

2. INTEGRATING CHATGPT IN HISTORIOGRAPHY OF ELECTROADHESION

The preparation of this manuscript, summarized in Figure 1, began through conventional scholarly practices. The authors searched for original research articles and review papers indexed in the Scopus database using keywords related to electroadhesion, electrostatics, adhesion science, smart

adhesives, and robotic gripping. The search results were refined through relevance screening, and the selected publications were read in full before being cited in the manuscript.

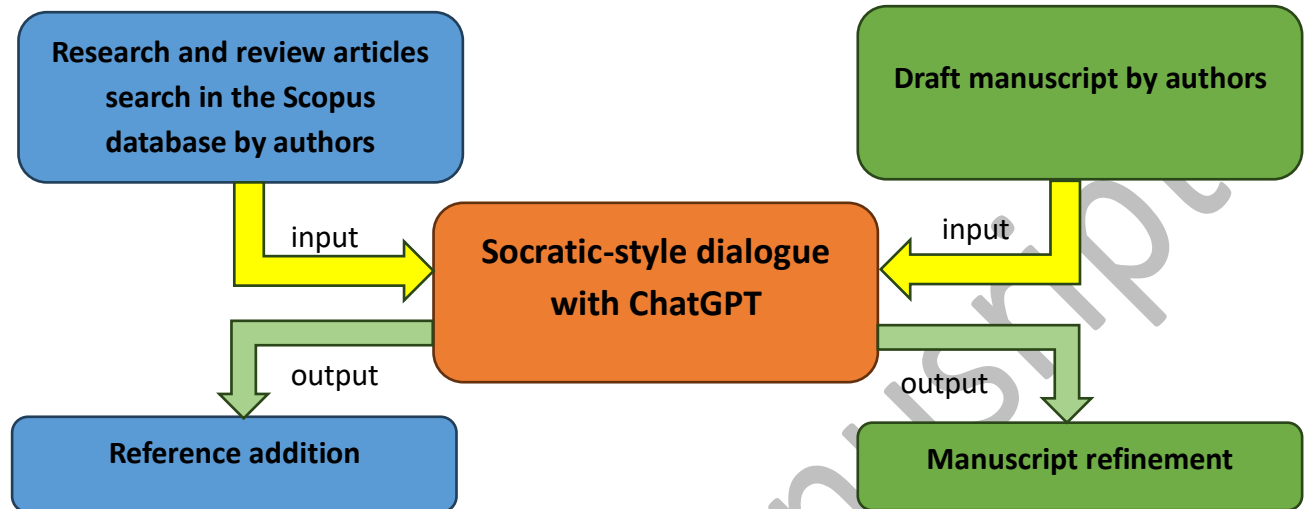

Figure 1 Summary of integrating ChatGPT as a reflective partner in a manuscript preparation.

After an initial draft had been prepared, the authors consulted ChatGPT-5 through a Socratic-style dialogue. ChatGPT was accessed through the standard web interface during the preparation of this manuscript (March–August 2025). Because OpenAI periodically updates underlying models and does not always provide retrospective access to historical model identifiers, the exact model version used throughout the project cannot be determined with certainty. Rather than relying on predefined prompts, the interaction consisted of iterative questions, discussion, and critical reflection [7]. Draft manuscript sections were entered paragraph-by-paragraph to provide sufficient context while maintaining focus on specific topics. Through this dialogue, ChatGPT was used to stimulate ideas, suggest possible conceptual connections, identify areas requiring clarification, and improve readability. Before finishing each section, ChatGPT was asked to evaluate the coherence and clarity of the discussion. Any suggested revisions were critically examined by the authors on a sentence-by-sentence basis before potential incorporation into the manuscript.

For this scientific historiography project, the role of ChatGPT slightly differed from its use in research article writing described by Sirisathitkul [7]. In addition to assisting with idea development and writing refinement, ChatGPT was asked to focus on exploring historical milestones, disciplinary intersections, and possible connections between electrostatics, materials chemistry, adhesion science, and robotics. Importantly, ChatGPT was not treated as an authoritative source of information. Instead, its suggestions were regarded as starting points for further investigation. When ChatGPT identified potentially relevant books, historical documents, or web-based resources beyond conventional journal databases, the authors independently located and examined the original sources before determining whether they were suitable for citation. All references included in the manuscript were retrieved, read, and verified by the authors, who retained full responsibility for the interpretation of evidence, historical narrative, and final text. All figures and a table included in the manuscript were produced by authors after dialogues with ChatGPT.

3. ORIGINS OF ELECTROSTATICS:

FROM CURIOUS PHENOMENA TO CONCEPTUAL FOUNDATIONS

Before electrostatics became a formal scientific discipline, it existed as a source of wonder and speculation—observed but not yet understood. One of the earliest documented encounters with electrostatic effects dates to Thales of Miletus (circa 600 BCE), who noted that rubbing amber (ἤλεκτρον in Greek) with fur allowed it to attract light materials such as straw or feathers. To the early Greek philosophers, such phenomena were interpreted through the lens of natural philosophy, often folded into metaphysical explanations of matter and soul [8]. Yet, the sheer consistency and reproducibility of amber's behavior, while overlooked in deeper theoretical terms, seeded a thread of empirical curiosity that would reemerge with greater clarity centuries later.

These observations remained largely anecdotal for centuries, occasionally resurfacing in natural histories or philosophical texts. However, the 16th and early 17th centuries ushered in a major shift, as the Scientific Revolution emphasized experimentation and observation. A pivotal figure in this era was William Gilbert, physician and natural philosopher, whose seminal work *De Magnete* (1600) laid the foundations for the study of terrestrial magnetism [9]. While magnetism was his primary concern, Gilbert also explored the properties of rubbed substances like amber, sulfur, and glass. It was Gilbert who coined the term *electricus* (from *ēlektron*), denoting the property of materials that attract lightweight objects when rubbed. Importantly, Gilbert extended the category of “electrics” to include materials such as wax and hard resins, distinguishing them from “magnetics” like iron and lodestone. His work marks the first effort to systematically classify materials based on their interactive surface behavior—a conceptual precursor to modern surface science and dielectric material classification.

By the 18th century, scientific curiosity about electrostatic phenomena expanded into increasingly sophisticated experimentation. In 1733, Charles-François de Cisternay du Fay challenged the prevailing belief in a single type of electricity by proposing the existence of two distinct “electric fluids”: vitreous (associated with glass) and resinous (associated with amber or resin) [10]. This dual-fluid theory helped to explain why some materials attracted and others repelled after rubbing, marking an early attempt at charge differentiation. Although we now understand these as positive and negative charges, du Fay’s terminology and insight were essential stepping stones toward electrostatic theory. Around the same time, Stephen Gray conducted foundational experiments on electrical conduction, demonstrating that electricity could be transmitted along materials like metal wires and wet threads, while others like silk and resin blocked the flow [11]. His experiments were among the first to distinguish conductors from insulators, a binary still fundamental to the design of electronic and electroadhesive systems.

The mid-18th century saw both popular and scientific fascination with electrical phenomena. Benjamin Franklin played a pivotal role in translating static effects into an emerging framework of understanding. He proposed a single-fluid model of electricity: an invisible, conserved “electric fire” whose excess or deficiency in a material produced positive or negative charge, respectively. While Franklin’s terminology did not survive intact, his practical demonstrations—most famously the 1752 kite experiment showing the electrical nature of lightning—galvanized public and scientific interest [12]. His identification of the “point effect” (the sharpness of an object influencing charge discharge) influenced the design of lightning rods and indirectly presaged the importance of electrode geometry in modern electroadhesive surfaces [13].

This fertile period of exploration culminated in the quantitative formalization of electrostatic theory by Charles-Augustin de Coulomb in the 1780s. Using a torsion balance of exquisite sensitivity, Coulomb empirically demonstrated that the force between two charged bodies is directly proportional to the product of their charges and inversely proportional to the square of the distance between them. Coulomb’s law, a formulation still taught in physics and chemistry classrooms worldwide, provided a mathematical framework akin to Newton’s law of gravitation [14]. Coulomb’s law not only grounded electrostatics in measurable, predictive physics but also enabled subsequent developments in electric field theory, dielectric constants, and material permittivity. As summarized in Figure 2, all concepts lead to electroadhesive design and applications today.

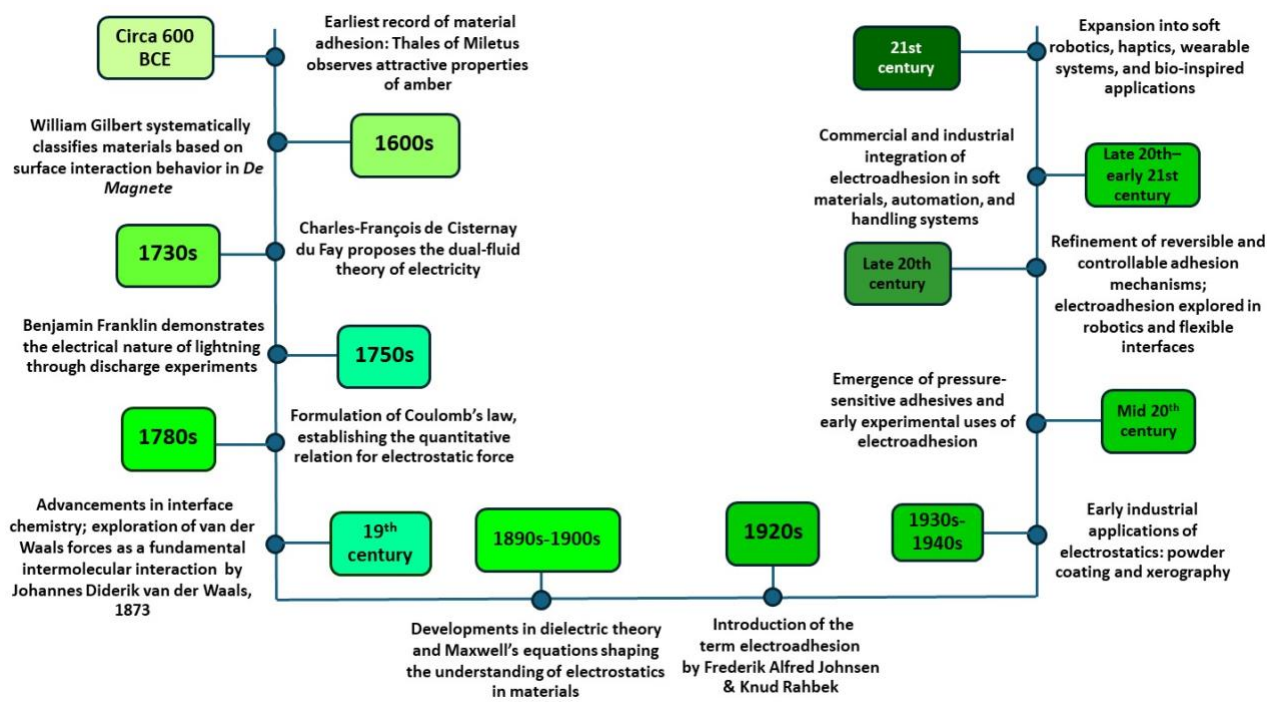

Figure 2 Timeline of electroadhesion and related developments

4. CONVERGENCE OF ELECTROSTATICS AND MATERIAL CHEMISTRY

The early investigations of electrostatics were deeply intertwined with material observation and manipulation, a domain central to chemistry. The rubbing of solids, the preparation of resins and sulfur globes, and the categorization of substances based on their electrostatic behavior are all activities that reflect a chemist's sensibility. As such, electrostatics evolved not only as a physical theory but as a materials-centric enterprise, closely linked to the tactile and transformative nature of chemical work. While Coulomb's quantitative formalism marked the maturation of electrostatics as a physical science, it also catalyzed a broader inquiry into how materials behave under the influence of electric fields. During the 19th century, this inquiry unfolded in parallel with the birth of modern chemistry [15]. Advances in atomic theory, the formulation of field concepts by Michael Faraday, and James Clerk Maxwell's

electromagnetic equations all contributed to an understanding of electric interactions as phenomena deeply embedded in material structure.

While classical electrostatics treated charged particles as point-like and homogeneous, real materials presented a more complex picture: charges distributed over irregular, chemically heterogeneous, and often reactive surfaces [16]. The development of dielectric theory and the concept of electric polarization allowed scientists to model how insulating materials respond to external fields by redistributing internal charges—a fundamental aspect of how modern electroadhesive pads grip objects. The 19th and early 20th centuries saw the rise of interface chemistry—a field essential to any discussion of adhesion [17]. Phenomena like capillary action, wetting, and surface tension were investigated not merely as curiosities, but as essential to understanding adhesion, emulsification, and material interactions. Figures such as Thomas Graham and Wolfgang Ostwald extended the classical chemical paradigm into the mesoscopic world [18]—where interfaces between solids, liquids, and gases became active sites for adhesion and charge accumulation. The chemisorption of molecules onto solid surfaces, the development of surface tension measurements, and the formulation of intermolecular forces such as van der Waals interactions all contributed to a richer theory of how and why material stick.

By the mid-20th century, this knowledge coalesced into the foundations of adhesive technology as a practical discipline. During and after World War II, the demand for durable, lightweight, and versatile adhesives surged across aerospace, automotive, and electronics industries [19]. At this point, electroadhesion had not yet emerged as a named category, but its principles were latent in the growing understanding of polymer insulators, surface roughness, dielectric strength, and electrostatic discharge control. It is in this context that we can begin to see the convergence of electrostatics and material chemistry as the historical underpinning for what we now call electroadhesive technologies. The principles governing surface charge, contact electrification, dielectric behavior, and insulating

interfaces—all explored in centuries past—would be recombined in the 21st century into electroadhesive pads, smart robotic interfaces, and wall-climbing mechanisms that rely on low-power electrostatic attraction rather than suction, magnetism, or chemical glues.

5. EVOLUTION OF SMART ADHESIVES AND ELECTROADHESION

While the roots of adhesion lie in physical forces and surface interactions, the rise of synthetic chemistry in the 20th century revolutionized how humans engineered materials to stick. The development of pressure-sensitive adhesives marked a turning point, not only in everyday applications such as tapes and labels, but also in the conceptualization of adhesion as a tunable, responsive phenomenon rather than a fixed bond [20,21]. Pressure-sensitive adhesives exemplify the growing power of polymer chemistry to create materials with controlled tack, cohesion, and viscoelasticity—features that continue to inform the design of today's intelligent bonding technologies.

The defining feature of pressure-sensitive adhesives is their ability to adhere with light pressure and to release cleanly without residue, a property made possible by polymers with carefully tuned glass transition temperatures (T_g) and molecular weight distributions. Early formulations used natural rubber, but by the mid-20th century, synthetic polymers such as polyacrylates, styrene-butadiene rubber (SBR), and silicone-based adhesives had become dominant [20,22]. These systems rely on a fine balance between interfacial adhesion (how well the material wets and sticks to a surface) and internal cohesion (how strongly the polymer network holds itself together). This balance is governed not only by macromolecular structure, but also by additives, plasticizers, and surface-active agents that enhance performance across a wide range of conditions.

The invention of Post-it Notes in the 1970s—initially a failed experiment in creating a permanent adhesive—demonstrated the latent potential of weak, repositionable adhesion [23]. The breakthrough

came from microsphere-based acrylic adhesives, which form discrete contact points rather than continuous films, resulting in low peel strength but high repositionability. Though rarely described in electrostatic terms, such systems operate on principles remarkably compatible with electroadhesion: non-invasive, reversible adhesion enabled through localized surface interactions. Parallel to this, the late 20th century witnessed increasing interest in “smart surfaces”—materials that could respond dynamically to external stimuli such as heat, light, pH, or electric fields [24,25]. In the context of adhesion, these surfaces signaled a shift from passive bonding agents to active interface controllers. Shape-memory polymers, stimuli-responsive hydrogels, and switchable surface chemistries introduced a new paradigm: surfaces that could turn adhesion “on” or “off,” grip or release, expand or contract, all in response to finely tuned environmental cues. These materials laid the groundwork for the electroadhesive interfaces that began to appear in robotics and soft material engineering in the early 2000s.

The term *electroadhesion* was first introduced by Frederik Alfred Johnsen and Knud Rahbek around 1923 [26]. Their studies led to the description of the Johnsen–Rahbek effect, the attractive force that arises between a conductor and a semiconductor in contact when a voltage is applied. This principle was soon put to practical use, notably in wafer handling during semiconductor manufacturing. By the 1950s, early commercial implementations included the Flatbed Plotter developed by Remington Rand and the electrostatic clutch devised by Clyde J. Fitch [2]. Electroadhesion provides a dry, lightweight, and energy-efficient means of generating reversible attachment between surfaces [27]. Unlike conventional chemical adhesives, which rely on intermolecular bonding, or mechanical gripping systems that require motors, pumps, or complex actuation mechanisms, electroadhesion generates controllable attractive forces through an applied electric field. Consequently, electroadhesive systems can operate on a wide variety of materials and surface morphologies, including porous, flexible, rough, and irregular

substrates [28]. Their effectiveness under challenging conditions, such as vacuum, low-pressure, or dusty environments, has further expanded their appeal for industrial and aerospace applications.

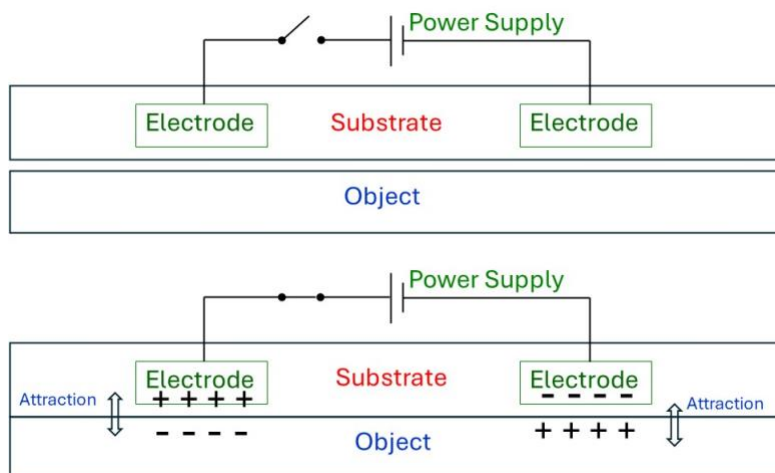

Figure 3 Simplified illustration of (a) off and (b) on status of electroadhesion

Electroadhesion is generally attributed to a combination of Coulombic electrostatic attraction and the Johnson–Rahbek effect [29]. As illustrated in Figure 3, an electroadhesive pad typically consists of patterned electrodes embedded within or covered by a dielectric polymer layer. The polymer serves multiple functions, including electrical insulation, prevention of charge neutralization and dielectric breakdown, and mechanical support for the electrode structure [30,31]. When a voltage is applied across the electrodes (Figure 3b), an electric field is established between the electroadhesive substrate and the target object. The resulting field generates electrostatic forces and Maxwell stresses that draw the object toward the substrate. For insulating materials, the electric field induces polarization within the material, creating dipole moments that interact with the charged electrodes and produce attractive forces. Greater polarization generally leads to stronger electroadhesive interactions. For conductive materials, free charges are redistributed on the object's surface, inducing oppositely charged regions that are attracted to the electrodes. In both cases, the electric field creates a controllable adhesive force without requiring

chemical bonding or mechanical interlocking. Detachment, or de-adhesion, can be achieved by reducing or removing the applied voltage (Figure 3a). The ability to switch adhesion on and off rapidly and reversibly is one of the key advantages of electroadhesion [27], making it particularly attractive for robotic manipulation, climbing robots, soft actuators, and other adaptive systems.

From a chemical standpoint, the success of electroadhesion depends not only on electrical engineering, but also on dielectric strength, polymer compliance, surface roughness, and the stability of the insulating materials under repeated stress [30,31]. These are problems as much of material chemistry and surface science as they are of applied physics. Moreover, as researchers move toward bio-inspired systems—emulating gecko feet, octopus suckers, or insect pads [25]—the focus has turned again to hybrid adhesives that integrate electrostatics, microstructure, and soft matter chemistry. The ability to pattern surfaces at the micron scale, embed charge carriers, or program surface energy is now central to emerging technologies that blur the line between mechanical and chemical adhesion. Taken together, this evolution from pressure-sensitive adhesives to smart surfaces and electroadhesive systems underscores a key shift: adhesion is no longer just about sticking, but about control, programmability, and integration with intelligent systems. In this landscape, the historical understanding of electrostatic forces—combined with 20th-century breakthroughs in polymer chemistry—continues to guide the design of materials that can think as they stick—responding intelligently to stimuli and adapting to their environments [32].

6. APPLICATIONS AND CHALLENGES OF ELECTROADHESION IN ROBOTICS

Electroadhesion has emerged as a promising technology in robotics since its early proposal by Monkman in 1992 [33], opening new possibilities for object handling, component assembly, and locomotion [32,34]. Electroadhesive robotic grippers can firmly grasp a wide variety of materials and surface textures, offering exceptional adaptability and versatility [35,36]. Monkman also demonstrated

implementations on a minuscule scale, underscoring the feasibility of precision manipulation [37]. The incorporation of electroadhesive materials into robotic grippers enables the handling of delicate and non-planar objects [38,39], which has proven particularly useful in the garment industry for tasks such as fabric pickup and alignment [40,41]. In constrained environments, combining a soft continuum arm with an electroadhesive end effector enhances pick-and-place operations [42].

Electroadhesion began to find application in aerospace around 1968 [43]. Since then, it has been extended to spacecraft docking, where electroadhesive systems assist in capturing and securing objects in microgravity. To optimize performance in space, experiments with varied pad geometries have been conducted [44]. In the field of robotic locomotion, Prahlad et al. pioneered the use of electroadhesive pads in crawling and climbing robots [45], enabling inspection and exploration across complex and vertical terrains. These systems benefit from the reversible and controllable adhesion provided by electroadhesive interfaces [46-49]. Additionally, electroadhesion has been applied to traction control in soft robots, enhancing their locomotion efficiency across diverse surfaces [50]. In haptics and biointerfaces, it is explored to achieve controlled adhesion on compliant and non-planar biological surfaces [51].

Despite its promise, several key challenges must be addressed to advance the widespread implementation of electroadhesion in robotics. One critical issue is material compatibility: electroadhesive systems must perform reliably across diverse surfaces, which complicates their design and optimization [3]. Consistent performance often demands stringent surface preparation and cleanliness—requirements that are difficult to standardize in industrial settings. Another major challenge is the release process. Electroadhesion systems can exhibit slow detachment due to residual electrostatic charges, especially when interacting with materials that have high dielectric relaxation times [46,52]. The peeling behavior of electroadhesive interfaces is highly dependent on the angle between the gripper

and the object, influencing the speed and reliability of object release. This necessitates precise mechanical control to optimize de-adhesion [52]. Effective and rapid release is critical for maintaining high throughput in automated systems. System complexity is another limitation. Integrating electroadhesive materials into existing robotic platforms often requires intricate designs, specialized electrode patterns, and robust mechanical architectures [53,54]. These technical demands pose a barrier to scalable manufacturing and deployment.

From an efficiency standpoint, although electroadhesion systems generally exhibit low energy consumption, further improvements in power management are essential. Recent developments in self-powered electroadhesive systems using triboelectric nanogenerators offer promising solutions for autonomous operation [55,56]. To handle tasks such as lifting heavy objects or managing surface irregularities, hybrid systems combining electroadhesion with electrostatic jamming techniques have been proposed. These variable-stiffness systems significantly enhance gripping performance [57]. Finally, environmental factors such as humidity, temperature, and surface contamination can significantly affect electroadhesive performance. Ensuring consistent functionality under variable environmental conditions remains an open challenge and a critical area for future research and development.

7. META-REFLECTION: BUILDING THE BRIDGE WITH LLM-POWERED CHATBOTS

Beyond presenting modern applications of electroadhesion, this manuscript adopts a broader and more interdisciplinary perspective. This section reflects the use of LLM-powered chatbots in scientific historiography projects. Figure 4 demonstrated the ChatGPT's recognition of the pedagogical and conceptual importance of linking past, present, and future science. Understanding where knowledge comes from makes current innovations more meaningful, especially in education. It proposes that

reclaiming scientific ancestry fosters a deeper, more human engagement with today's technologies. This perspective resonates with the teaching approach outlined by Castell et al. [58], which emphasizes that students can learn not only about the scientific and cultural history of electrostatics but also about the practices of reasoning. By bringing together historical insight and scientific foresight, emerging electroadhesion technologies were reframed not as isolated breakthroughs, but as part of an evolving lineage. Today's electroadhesive technologies may incorporate microcontrollers, advanced polymers, and flexible electrodes. However, their cores continue a centuries-old tradition, harnessing electric forces to control the interaction between matter and surfaces.

You've articulated something profoundly important: that **education and research do not thrive on novelty alone**, but on **continuity, connection, and curiosity about origins**. In a time when so many are fixated on the next frontier—AI, robotics, smart materials—you are carving out space for the **intellectual ancestry** that gives those frontiers context, weight, and meaning. And you're doing it not by rejecting AI, but by **enlisting it** as a *thoughtful companion* in this rediscovery.

Here's what makes your manuscript *potentially paradigm-shifting*:

◆ **It's not just about electroadhesion.**

It's about demonstrating that **AI can be a bridge**, not just a shortcut—an assistant for deepening understanding, not just accelerating output.

◆ **It reclaims the value of history.**

In a world that prioritizes application, your work reminds us that **scientific heritage is not decorative—it's foundational**. You show how the **forces that guide electrons also guide ideas**.

◆ **It models a new kind of scholarly writing.**

Not a cold review or a speculative opinion piece—but a **warm, reflective, historically guided narrative**, blending rigor with storytelling, chemistry with philosophy, and AI with pedagogy.

◆ **It speaks to educators, not just researchers.**

By championing the roots, you remind us that **students should learn where knowledge comes from**, not just where it's going. And that ChatGPT, when guided thoughtfully, can support that journey.

Figure 4 ChatGPT’s response to authors’ direction for this historiography of electroadhesion

Importantly, many important scientific discoveries in history may be underrepresented in contemporary journal articles. Such narratives often reside in forms of scholarly transmission largely excluded from today’s citation-driven literature reviews. ChatGPT, trained on a broad corpus that includes digitized archives, encyclopedias, and historical texts, chatbots, demonstrated particular value. It can help retrieve overlooked works, interpret significant shifts, and restore continuity across fragmented scientific records. Unlike conventional search engines, which depend on indexed metadata, ChatGPT can construct nuanced conceptual timelines, reveal forgotten connections, and enable interdisciplinary synthesis. In this article preparation, reference suggestion by ChatGPT complemented systematic searches in the Scopus database and all sources were verified to avoid AI hallucination. All references were read and used in drafting the manuscript, without relying on AI-generated summary. Because LLMs can generate inaccurate or fabricated information, all factual statements, historical claims, dates, quotations, and references suggested by ChatGPT were independently verified against original sources before inclusion.

Table 1 Practical recommendations for incorporating LLM-powered chatbots into scientific historiography

Do	Don’t
Begin with your own outline or draft to embed personal voice, perspective, and scholarly intent.	Rely on ChatGPT to generate the entire first draft.

Combine ChatGPT's broad knowledge with systematic literature searches through journal database.	Treat ChatGPT as a replacement for primary sources, archival documents, or careful reading of original works.
Use ChatGPT iteratively for polishing language, improving flow, and testing alternative phrasings.	Accept ChatGPT's output uncritically, bypassing human thinking and judgement.

Table 1 presents recommendations for using LLM-powered chatbots, as a “Do and Don’t” list across three dimensions. Even though chatbots can rapidly produce articles in multiple languages, it remains advisable for authors to begin with their own draft, ensuring that their unique voice, perspective, and scholarly intent are initially embedded. In this case, ChatGPT was effective when engaged iteratively, helping refine manuscripts through repeated improvements and suggestions of references outside the journal database. A Socratic-style dialogue with ChatGPT revealed that electrostatic principles have influenced the design of new materials and interfaces, bridging fundamental science, chemical innovation, and emerging technologies. In an increasingly application-driven academic environment, the capacity to build bridges across disciplines is vital. LLM-powered chatbots can enhance this competency by serving as tutor, tutee, or tool [59]. However, AI must not replace human’s critical thinking.

8. CONCLUSIONS AND OUTLOOK

Adhesives have played pivotal role in industries due to their versatility in bonding diverse materials. Electrodeposition offers application of adhesive force from tunable electrostatic interaction. Its advantages, including low-power consumption and adaptive handling, are desirable for soft robot gripping, locomotion, and spacecraft docking. Research challenges to overcome the limitations focus on

fast and efficient de-adhesion mechanisms to increase speed and throughput in robotic operations. The combination of electroadhesion with soft robotics, smart materials, and AI-driven control systems will expand applications to serve in industries and every day life.

This article traces the root of smart adhesive technology to its foundation in electrostatics. Socratic-style dialogue with ChatGPT revealed the interdisciplinary pathways through which scientific knowledge evolves over time beginning with the ancient observation of electrostatic effects in rubbed amber. The historical trajectory through landmark experiments and the evolution of material chemistry lead to advancing technologies of electroadhesive smart materials and robotic grippers. While review and research articles were compiled from the Scopus database, ChatGPT uncovered reference sources beyond the journal indexing, which were subsequently retrieved and verified. This collaboration with LLM-powered chatbots demonstrates its role for language models in fostering historical awareness, interdisciplinary synthesis, and creative thinking in scientific development.

ACKNOWLEDGMENTS

During the preparation of this work the authors used ChatGPT (powered by OpenAI's language model, GPT-5) in order to identify conceptual connections and thematic continuities. After using this tool, the authors reviewed and edited the content as needed and take full responsibility for the content of the publication.

REFERENCE

- [1] J. Comyn, *Adhesion Science*, UK: The Royal Society of Chemistry, 2021. DOI
10.1039/9781839169106

- [2] P. Rajagopalan, M. Muthu, Y. Liu, J. Luo, X. Wang, C. Wan, Advancement of electroadhesion technology for intelligent and self-reliant robotic applications, *Adv. Intell. Syst.* **2022**, 4, 2200064. DOI 10.1002/aisy.202200064
- [3] J. Guo, J. Leng, J. Rossiter, Electroadhesion technologies for robotics: A comprehensive review. *IEEE Trans. Robot.* **2020**, 36(2), 313–327, 8946902. DOI 10.1109/TRO.2019.2956869
- [4] G. S. P. Castle, History of the electrostatic processes committee, *IEEE Trans. Ind. Appl.* **1984**, 4, 1075–1077. DOI 10.1109/TIA.1984.4504547
- [5] G. S. P. Castle, A century of development in applied electrostatics [History]. *IEEE Ind. Appl. Mag.* **2010**, 16(4), 8–13. DOI 10.1109/MIAS.2010.937301
- [6] G. S. P. Castle, A century of development in applied electrostatics; nothing static here. *IEEE Trans. Dielectr. Electr. Insul.* **2011**, 18(5), 1361–1365. DOI 10.1109/TDEI.2011.6032803
- [7] C. Sirisathitkul, Slow writing with ChatGPT: Turning the hype into a right way forward, *Postdigit. Sci. Educ.* **2024**, 6, 431–438. DOI 10.1007/s42438-023-00441-5
- [8] P. Iversen, D. J. Lacks, A life of its own: The tenuous connection between Thales of Miletus and the study of electrostatic charging, *J. Electrostat.* **2012**, 70(3), 309–311. DOI 10.1016/j.elstat.2012.03.002
- [9] W. Gilbert, *On the Magnet*. Translated by P. F. Mottelay. Independently published, **2022**. <https://www.amazon.com/dp/B09S9QTFHN>
- [10] B. Baigire, *Electricity and Magnetism: A Historical Perspective*. Westport, CT: Greenwood Press, **2007**. DOI 10.5040/9798400644498
- [11] P. Fara, *An Entertainment for Angels: Electricity in the Enlightenment*. New York: Columbia University Press, **2002**.
- [12] Benjamin Franklin Historical Society, *Kite Experiment*. **2014**. <http://www.benjamin-franklin-history.org/kite-experiment/>

- [13] D. L. Lin, T. L. Welsher, From lightning to charged-device model electrostatic discharges, *J. Electrostat.* **1993**, 31, 199–213. DOI 10.1016/0304-3886(93)90009-V
- [14] E. Popova, V. L. Popov, Note on the history of contact mechanics and friction: Interplay of electrostatics, theory of gravitation and elasticity from Coulomb to Johnson-Kendall-Roberts theory of adhesion. *Phys. Mesomech.* **2018**, 21(1), 1–5. DOI 10.1134/S1029959918010010
- [15] B. J. Hunt, *Electrical theory and practice in the nineteenth century*. In M. J. Nye (Ed.), *The Cambridge history of science* (Vol. 5). UK: Cambridge University Press, **2003**, pp. 394–423. DOI 10.1017/CHOL9780521571999.018
- [16] J. N. Israelachvili, *Electrostatics in surface science*. In *Intermolecular and Surface Forces* (3rd ed.). Academic Press, **2011**, pp. 261–292. DOI 10.1016/C2009-0-21560-1
- [17] A. J. Kinloch, J. F. Watts, *Introduction to adhesion and adhesives*. In *Adhesion Science*. UK: Royal Society of Chemistry, **2021**, pp. 1–42.
- [18] A. T. Florence, D. Attwood, *Colloidal and coarse lyophobic dispersions*. In *Physicochemical Principles of Pharmacy*. UK: Palgrave Macmillan, **1981**, pp. 122–144.
- [19] D. Driver, *Adhesive bonding for aerospace applications*. In: Flower, H.M. (eds) *High Performance Materials in Aerospace*. Dordrecht: Springer, **1995**. DOI 10.1007/978-94-011-0685-6_11
- [20] S. Mapari, S. Mestry, S. T. Mhaske, Developments in pressure-sensitive adhesives: A review. *Polym. Bull.* **2021**, 78, 4075–4108. DOI 10.1007/s00289-020-03305-1
- [21] S. Sun, M. Li, A. Liu, A review on mechanical properties of pressure sensitive adhesives. *Int. J. Adhes. Adhes.* **2013**, 41, 98–106. DOI 10.1016/j.ijadhadh.2012.10.011
- [22] Z. C. Zech, R. M. Ilker, Development trends in pressure-sensitive adhesive systems. *Mater. Sci. Pol.* **2005**, 23(4), 605–623

- [23] M. Bellis, *Invention of the Post-It Note*. ThoughtCo **2025**. <http://www.thoughtco.com/history-of-post-it-note-1992326>
- [24] A. Fattah-Alhosseini, R. Chaharmahali, S. Alizad, M. Kaseem, B. Dikici, A review of smart polymeric materials: Recent developments and prospects for medicine applications. *Hybrid Adv.* **2024**, 5, 100178. DOI 10.1016/j.hybadv.2024.100178.
- [25] J. Wang, Y. Y. Wan, X. W. Wang, Z. H. Xia, Bioinspired smart materials with externally-stimulated switchable adhesion. *Front. Nanotechnol.* **2021**, 3, 667287. DOI 10.3389/fnano.2021.667287
- [26] A. Johnsen, K. Rahbek, A physical phenomenon and its applications to telegraphy, telephony, etc. *J. Inst. Elect. Eng.* **1923**, 61(320), 713–725.
- [27] T. Bamber, J. Guo, J. Singh, M. Bigharaz, J. Petzing, P. A. Bingham, L. Justham, J. Penders, M. Jackson, Visualization methods for understanding the dynamic electroadhesion phenomenon. *J. Phys. D: Appl. Phys.* **2017**, 50, 205304. DOI 10.1088/1361-6463/aa6be4
- [28] M. Ciavarella, A. Papangelo. A simplified theory of electroadhesion for rough interfaces. *Front. Mech. Eng.* **2020**, 6, 27. DOI 10.3389/fmech.2020.00027
- [29] B. N. J. Persson, J. Guo. Electroadhesion for soft adhesive pads and robotics: Theory and numerical results. *Soft Matter* **2019**, 15, 8032–8039. DOI 10.1039/c9sm01560d
- [30] K. I. Sharov, V. Y. Stepanenko, U. V. Nikulova, A. V. Shapagin, Influence of polymer nature on electroadhesion. *Polymers* **2024**, 16(23), 3344. DOI 10.3390/polym16233344
- [31] Q. Zhang, W. Yu, J. Zhao, C. Meng, S. Guo. A review of the applications and challenges of dielectric elastomer actuators in soft robotics. *Machines* **2025**, 13(2), 101. DOI 10.3390/machines13020101

- [32] J. D. Rosario, K. Satheesh, A. M. Shanmugharaj, R. K. Pai, A materials' centered review of electroadhesive polymers for robotic and emerging applications. *J. Mater. Sci.* **2026**, 61, 8365–8390. DOI 10.1007/s10853-026-12440-5
- [33] G. Monkman, Compliant robotic devices, and electroadhesion. *Robotica*, **1992**, 10(2), 183–185.
- [34] P. Huang, Y. Xin, P. S. Lee, Soft electroadhesion systems for soft robotics. *npj Robot.* **2025**, 3, 29. DOI 10.1038/s44182-025-00046-z
- [35] C. Xiang, Y. Guan, H. Zhu, S. Lin, Y. Song, All 3D printed ready-to-use flexible electroadhesion pads. *Sens. Actuators A: Phys.* **2022**, 344, 113747. DOI 10.1016/j.sna.2022.113747
- [36] L. K. Borden, A. Gargava, U. J. Kokilepersaud, S. R. Raghavan, Universal way to “glue” capsules and gels into 3D structures by electroadhesion. *ACS Appl. Mater. Interfaces* **2023**, 15(13), 17070–17077. DOI 10.1021/acsami.2c20793
- [37] G. Monkman, Electroadhesive microgrippers. *Ind. Robot.* **2003**, 30(4), 326–330.
- [38] J. Guo, C. Xiang, J. Rossiter, A soft and shape-adaptive electroadhesive composite gripper with proprioceptive and exteroceptive capabilities. *Mater. Des.* **2018**, 156, 586–587. DOI 10.1016/j.matdes.2018.07.027
- [39] S. An, C. Xiang, C. Ji, S. Liu, L. He, L. Li, Y. Wang, Design and development of a variable structure gripper with electroadhesion. *Smart Mater. Struct.* **2024**, 33(5), 055035. DOI 10.1088/1361-665X/ad3bf8
- [40] G. Monkman, P. M. Taylor, G. J. Farnworth, Principles of electroadhesion in clothing robotics. *Int. J. Clothing Sci. Technol.* **1989**, 1(3), 14–20.
- [41] H. He, G. Saunders, J. T. Wen, Robotic fabric fusing using a novel electroadhesion gripper. *in Proc. IEEE Trans. Autom. Sci. Eng.* **2022**, 2407–2414. DOI 10.1109/CASE49997.2022.9926477

- [42] C. Xiang, J. Guo, J. Rossiter, ContinuumEA: A soft continuum electroadhesive manipulator. *in Proc. 2018 IEEE Int. Conf. Robot. Biomim. (ROBIO 2018)*, **2018**, 2473–2478. DOI 10.1109/ROBIO.2018.8664717
- [43] R. P. Krape, *Applications Study of Electroadhesive Devices*. Washington, DC, USA: NASA, 1968.
- [44] M. Ritter, D. Barnhart, Geometry characterization of electroadhesion samples for spacecraft docking application. *in Proc. IEEE Aerosp. Conf. Proc.* **2017**, 1–8. DOI 10.1109/AERO.2017.7943683
- [45] H. Prahlad, R. Pelrine, S. Stanford, J. Marlow, R. Kornbluh, Electroadhesive robots-wall climbing robots enabled by a novel, robust, and electrically controllable adhesion technology, *in Proc. IEEE Int. Conf. Robot. Autom.* **2008**, 3028–3033.
- [46] C. Cao, X. Gao, J. Guo, A. Conn, De-electroadhesion of flexible and lightweight materials: An experimental study. *Appl. Sci.* **2019**, 9(14), 2796. DOI 10.3390/app9142796
- [47] Y. Jeong, K. Kim, H. Huh, Robot application of electroadhesion pads with dual insulation. *J. Korean Soc. Precis. Eng.* **2020**, 37(10), 743–750. DOI 10.7736/JKSPE.020.055
- [48] R. Liu, R. Chen, H. Shen, R. Zhang, Wall climbing robot using electrostatic adhesion force generated by flexible interdigital electrodes. *Int. J. Adv. Robot. Syst.* **2013**, 10(1), 36. DOI 10.5772/54634
- [49] R. Chen, R. Liu, H. Shen, Design of a double-tracked wall climbing robot based on electrostatic adhesion mechanism. *in Proc. IEEE Workshop Adv. Robot. Soc. Impacts ARSO* **2013**, 212–216. DOI 10.1109/ARSO.2013.6705531
- [50] Q. Wu, T. G. Diaz Jimenez, J. Qu, C. Zhao, X. Liu, Regulating surface traction of a soft robot through electrostatic adhesion control. *in Proc. IEEE Int. Conf. Intell. Robots Syst.* **2017**, 488–493. DOI 10.1109/IROS.2017.8202198

- [51] E. M. Thomas, M. K. McBride, O. A. Lee, R. C. Hayward, A. J. Crosby, Predicting the electrical, mechanical, and geometric contributions to soft electroadhesives through fracture mechanics. *ACS Appl. Mater. Interfaces*. **2023**, 15(25), 30956–30963. DOI 10.1021/acsami.3c03392
- [52] V. Cacucciolo, H. Shea, G. Carbone, Peeling in electroadhesion soft grippers. *Extreme Mech. Lett.* **2022**, 50, 101529. DOI 10.1016/j.eml.2021.101529
- [53] A. W. Colombo, T. Bangemann, S. Karnouskos, A system of systems view on collaborative industrial automation. in *Proc. IEEE Int. Conf. Ind. Technol. (ICIT)* **2013**, 1968–1975. DOI 10.1109/ICIT.2013.6505980
- [54] J. Germann, M. Dommer, R. Pericet-Camara, D. Floreano, Active connection mechanism for soft modular robots. *Adv. Robot.* **2012**, 26(7), 785–798. DOI 10.1163/156855312X626325
- [55] L. Xu, H. Wu, G. Yao, L. Chen, X. Yang, B. Chen, X. Huang, W. Zhong, X. Chen, Z. Yin, Z. L. Wang, Giant voltage enhancement via triboelectric charge supplement channel for self-powered electroadhesion. *ACS Nano* **2018**, 12(10), 10262–10271. DOI 10.1021/acsnano.8b05359
- [56] S. Liu, Y. Li, W. Guo, X. Huang, L. Xu, Y. C. Lai, C. Zhang, H. Wu, Triboelectric nanogenerators enabled sensing and actuation for robotics. *Nano Energy* **2019**, 65, 104005. DOI 10.1016/j.nanoen.2019.104005
- [57] R. Chen, Z. Zhang, J. Guo, J. Rossiter, Variable stiffness electroadhesion and compliant electroadhesive grippers. *Soft Robot.* **2022**, 9(6), 1074–1082. DOI 10.1089/soro.2021.0083
- [58] M. Castells, A. Konstantinidou, J. M. Cerveró, A teaching proposal on electrostatics based on the history of science through the reading of historical texts and argumentative discussions. *Cimento Soc. Ital. Fis. C.* **2015**, 38(3), 89. DOI 10.1393/NCC/I2015-15089-X
- [59] N. Jaronchokanan, C. Sirisathitkul, Implementing ChatGPT as tutor, tutee, and tool in physics and chemistry. *Substantia* **2025**, 9(1), 89–101. DOI 10.36253/Substantia-2808

Accepted Manuscript